

ELVA-1 GOLA SERIES GAUSSIAN OPTICS LENS ANTENNAS

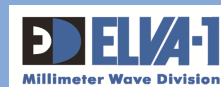

DATA SHEET
Frequency ranges
18 ÷ 400 GHz

GAUSSIAN OPTICS LENS ANTENNAS KEY FEATURES:

Up to 400 GHz spectrum

ELVA-1 series GOLA antennas are available in 12 subbands from 18 GHz to 400 GHz.

The on-shelf products are up to 235 GHz, the subband 235 to 400 GHz could be supplied upon request.

Various gain levels

The Gaussian Optics Lens Antennas are available in various gain levels for each subband. The typical gain levels are within 25 to 55 dBi depending on frequency and size.

Low sidelobes and VSWR make ELVA-1 antennas a worthy choice.

High Quality

The radiation patterns are characterized by circular symmetry and high efficiency.

Polarization options are single (linear or circular) and dual polarization. Spot beam focus GOLA also offered upon request.

General Description

Gaussian optics is named after mathematician and physicist Carl Friedrich Gauss who gave in 1840 the first analysis on the formation of images under a paraxial approximation, later called as Gaussian optics.

Today shaped pieces of microwave-transparent material are used in the GOLA antenna systems to bend and focus the radio waves by refraction, as an optical lens does if for light. These antennas are much more efficient compare to conventional conical horn antennas: for the same size a gain improvement could be +10 dB much with a very narrow beamwidth of about 1 degree. Often GOLA antennas are used for near-field applications such as plasma diagnostics and material properties.

ELVA-1 offers on-shelf and custom-designed GOLA antennas, obtaining orders for a wide range of radiation pattern requirements.



Applications

- Plasma diagnostics
- Radars and remote sensing
- Material properties research
- Communication systems
- Surveillance systems



How to order

Specify Model Number **GOLA-XX/C**, where:

XX - number of waveguide standard (Ex. 10 for WR-10 and 06 for WR-06)

C – Gain, dBi

Also, specify other specific parameters if required (polarization, spot beam focus, etc.).

GOLA SPECIFICATIONS

Parameter	Value
Frequency, GHz	18 to 400
Gain, dBi	25 to 55.5 (depending on frequency range)
VSWR (typ)	1.5:1
Sidelobes, dB (typ)	23
Net efficiency (typ)	50%
Dimensions	Depends on selected frequency of operation and gain (maximum aperture size 270 mm)

Model Number	Frequency, GHz	Waveguide	Flange	Gain, dBi
GOLA-K	18-26.5	WR-42	UG-595/U	25 to 31
GOLA-Ka	26.5-40	WR-28	UG-595/U	25 to 34.5
GOLA-Q	33-50	WR-22	UG-383/M	25 to 36
GOLA-U	40-60	WR-19	UG-383/U-M	25 to 38
GOLA-V	50-75	WR-15	UG-385/U	25 to 40
GOLA-E	60-90	WR-12	UG-387/U	25 to 41.5
GOLA-W	75-110	WR-10	UG-387/U-M	25 to 43.5
GOLA-F	90-140	WR-08	UG-387/U-M	25 to 45
GOLA-D	110-170	WR-06	UG-387/U-M	25 to 47
GOLA-G	140-220	WR-05	UG-387/U-M	25 to 49
GOLA-04	170-260	WR-04	UG-387/U-M	25 to 50.5
GOLA-03	220-235	WR-03	UG-387/U-M	25 to 53
GOLA-02	Up to 400	WR-2.8	Call	

EXAMPLE OF SPECIFICATIONS AND SIZES GIVEN FOR GOLA-03

Model	GOLA-03		
Frequency range, GHz	220 to 325		
Gain, dBi	35	42	50
Diameter, mm	35	70	195
Waveguide/Flange	WR-3.4 (the same as WR-03)/UG-387/U-M		

Outline drawings, mm

GOLA-03 35 dBi

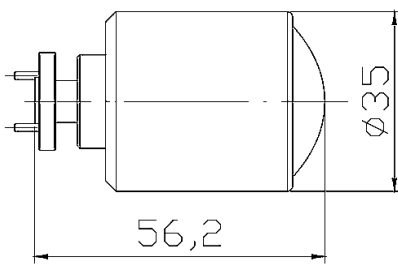

GOLA-03 42 dBi

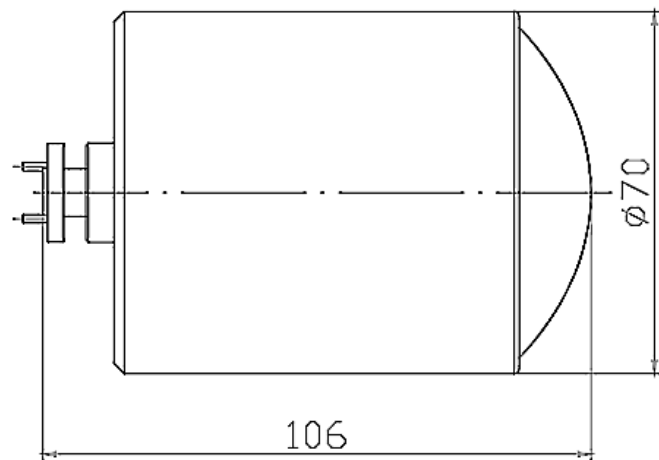

GOLA-03 50 dBi

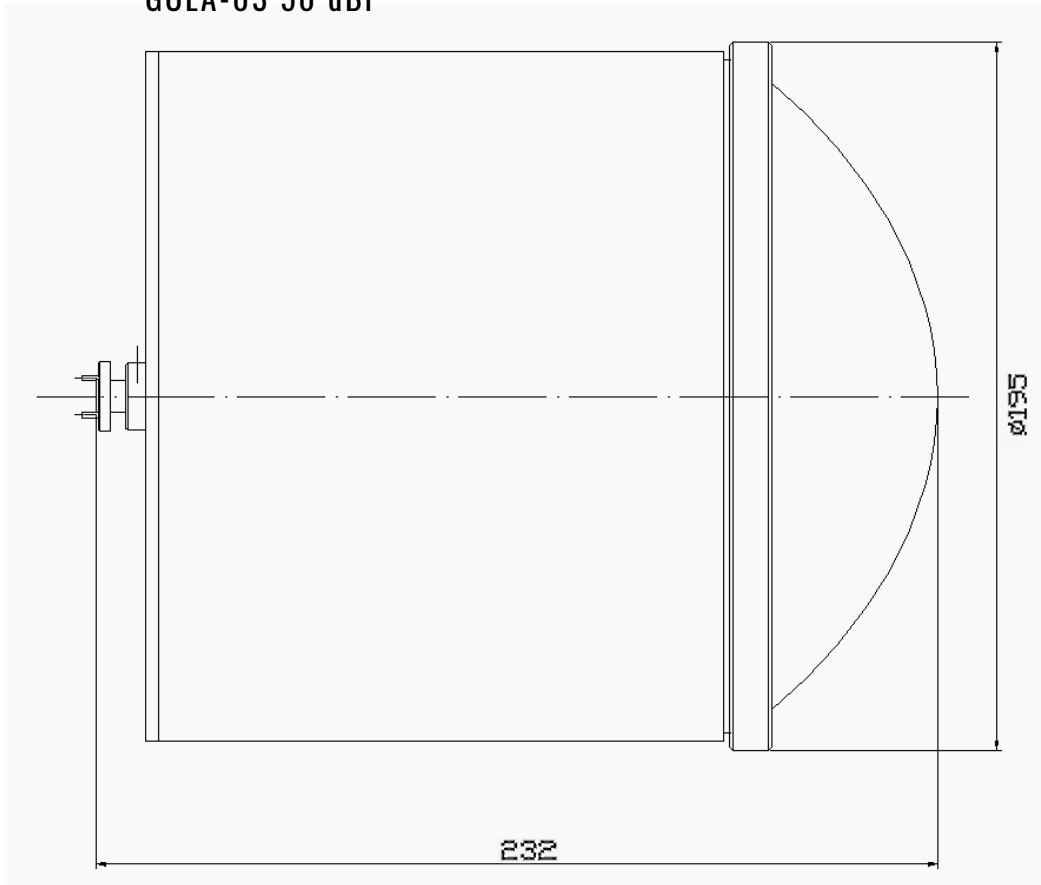

EXAMPLE OF PATTERN DIAGRAMS GIVEN FOR GOLA-03/42

GOLA-03/42 @220 GHz

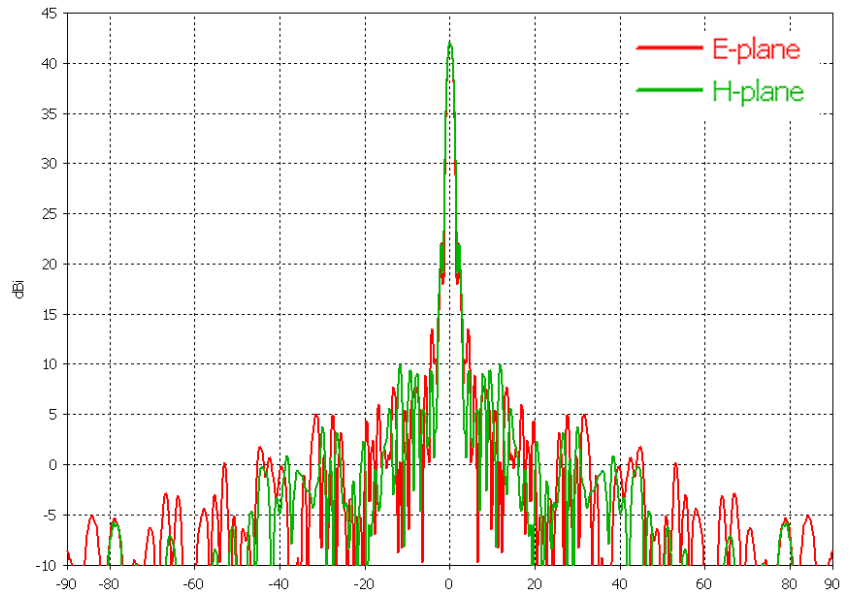

GOLA-03/42 @272.5 GHz

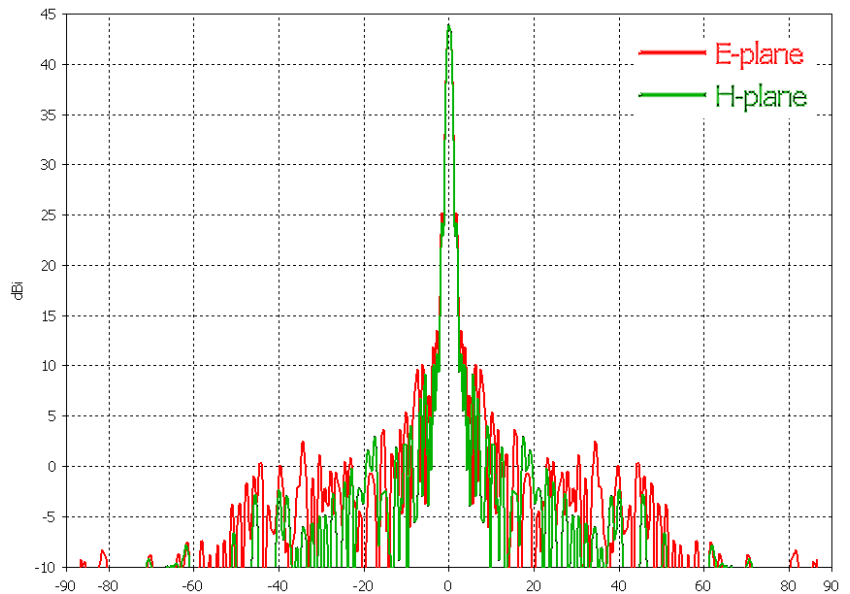

GOLA-03/42 @325 GHz

